

\*ROHS COMPLIANT

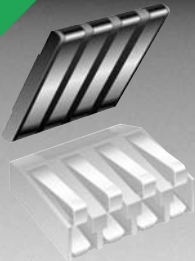

**BOURNS®**

## Features

- 2.54 mm pitch & height
- 2 to 6 precious metal contacts
- End-to-end stackable
- Twin hot contacts (symmetrical pad layout)
- Pick & place compatible
- High cycle life

- RoHS compliant\*

## 70AA/Female - Modular Contact

### Materials & Finishes

Insulator ....Glass reinforced thermoplastic,  
UL 94V-0 rated, black  
Contact .....Copper alloy  
Finish  
Underplating .....30 μ" - 60 μ" nickel  
Contact Area.....30 μ" Au over nickel

### Operating Characteristics

Electrical  
Current Rating .....3 A/contact  
Voltage Rating.....60 V  
Contact Resistance.....30 mohms max.  
Dielectric Voltage .....AC 500 V  
Insulating Resistance...1000 Mohms min.  
Operating Temperature...-55 °C to 125 °C  
Mechanical  
Durability .....10,000 cycles min.

### How to Order

**70AA J - 4 - F 0 G**

Model \_\_\_\_\_  
Terminal Style \_\_\_\_\_  
J = SMT  
Number of Contacts (N) \_\_\_\_\_  
2 through 6  
Gender \_\_\_\_\_  
F = Female  
Options \_\_\_\_\_  
0 = Standard  
1 = Locating Pins  
Packaging Option \_\_\_\_\_  
\_ = Tube (240/N pcs. or 240 contacts per tube)  
G = Embossed Tape (750 pcs. per reel)

### Product Dimensions

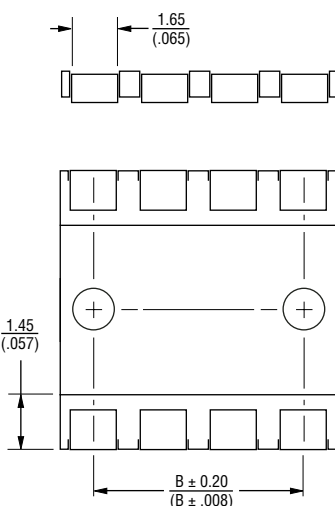
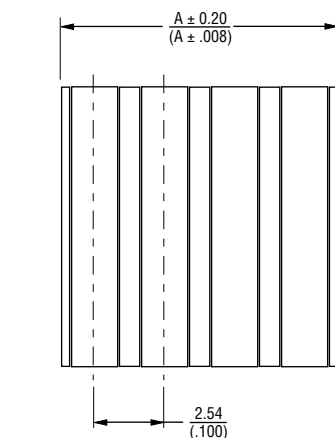

### Standard Version (-0)

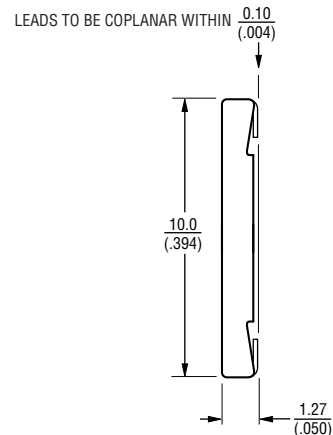

### Locating Pins Version (-1)

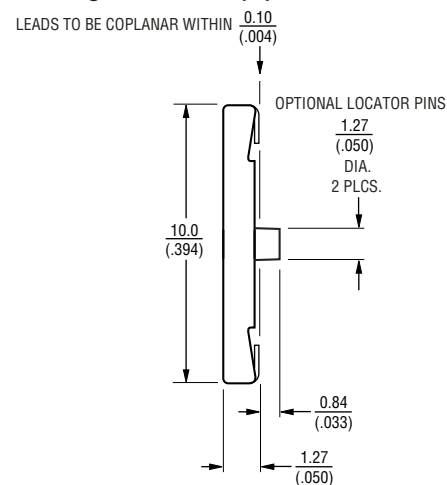

### Recommended PWB Layout

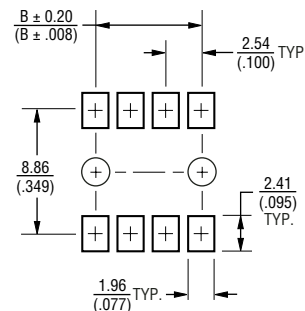

Number of Contacts	Dimension A	Dimension B
2	$\frac{4.98}{(.196)}$	$\frac{2.54}{(.100)}$
3	$\frac{7.52}{(.296)}$	$\frac{5.08}{(.200)}$
4	$\frac{10.06}{(.396)}$	$\frac{7.62}{(.300)}$
5	$\frac{12.60}{(.496)}$	$\frac{10.16}{(.400)}$
6	$\frac{15.14}{(.596)}$	$\frac{12.70}{(.500)}$

TOLERANCES:  $\frac{0.3}{(.012)}$  UNLESS OTHERWISE NOTED

DIMENSIONS ARE:  $\frac{\text{MILLIMETERS}}{\text{(INCHES)}}$

\*RoHS Directive 2002/95/EC Jan 27 2003 including Annex. Specifications are subject to change without notice.

Customers should verify actual device performance in their specific applications.

# 70AA/Female - Modular Contact

**BOURNS®**

## Packaging Specifications

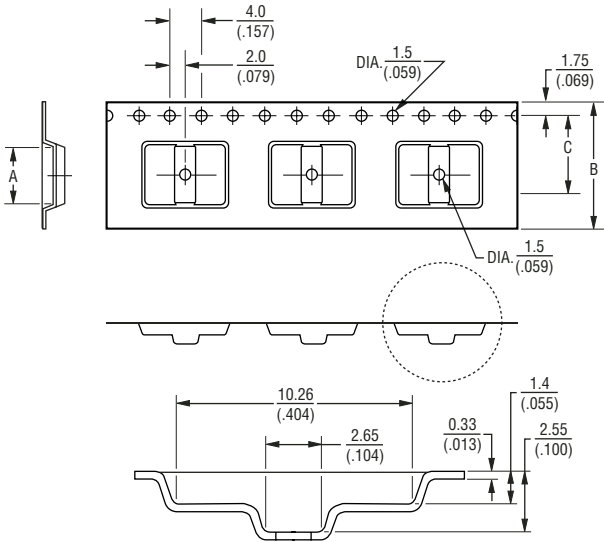

No. of Contacts	Dimension A	Dimension B	Dimension C
2	5.23 (.206)	16.0 (.630)	7.5 (.295)
3	7.77 (.306)	16.0 (.630)	7.5 (.295)
4	10.31 (.406)	24.0 (.945)	11.5 (.453)
5	12.85 (.506)	24.0 (.945)	11.5 (.453)
6	15.39 (.606)	24.0 (.945)	11.5 (.453)

DIMENSIONS ARE:  $\frac{\text{MILLIMETERS}}{\text{(INCHES)}}$

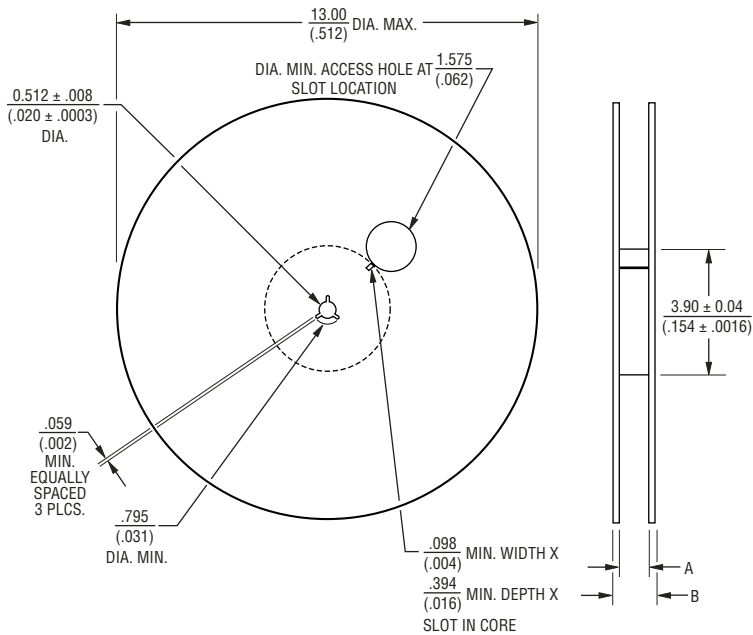

No. of Contacts	Dimension A	Dimension B (Max.)
2	.646 (.025)	.882 (.035)
3	.646 (.025)	.882 (.035)
4	.961 (.038)	1.197 (.047)
5	.961 (.038)	1.197 (.047)
6	.961 (.038)	1.197 (.047)

REV. 02/07

Specifications are subject to change without notice.  
Customers should verify actual device performance in their specific applications.